



NUP 309 ECML

- SKF Explorer

Cylindrical roller bearings, single row

Bearing data

Tolerances,
Normal (metric), P6, Normal (inch),
Radial internal clearance,
cylindrical bore, tapered bore,
Axial internal clearance,
NUP, NJ + HJ

Bearing interfaces

Seat tolerances for standard conditions,
Tolerances and resultant fit

Technical specification

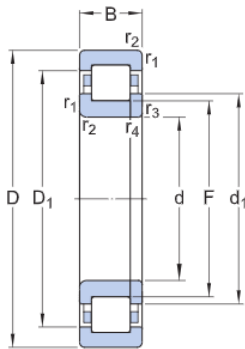

DIMENSIONS

d	45 mm	Bore diameter
D	100 mm	Outside diameter
B	25 mm	Width
d1	≈64.4 mm	Shoulder diameter of inner ring
D1	≈83.75 mm	Shoulder diameter of outer ring
F	58.5 mm	Chamfer dimension of loose flange ring
r1,2	min.1.5 mm	Chamfer dimension
r3,4	min.1.5 mm	Chamfer dimension of loose flange ring

ABUTMENT DIMENSIONS

da	min.54 mm	Diameter of spacer sleeve
db	min.67 mm	Diameter of shaft abutment
Da	max.91.4 mm	Diameter of housing abutment
ra	max.1.5 mm	Radius of fillet

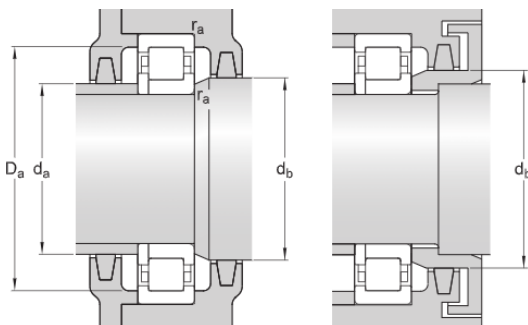

CALCULATION DATA

Basic dynamic load rating	C	106 kN
Basic static load rating	C ₀	91.5 kN
Fatigue load limit	P _u	11.8 kN
Reference speed		7 500 r/min
Limiting speed		13 000 r/min
Minimum load factor	k _r	0.23
Limiting value	e	0.2
Axial load factor	Y	0.6

MASS

Mass	1.04 kg
------	---------

More information

<p>Product details</p> <ul style="list-style-type: none"> Designs and variants Bearing data Loads Temperature limits Permissible speed Design considerations Designation system 	<p>Engineering information</p> <ul style="list-style-type: none"> Principles of rolling bearing selection General bearing knowledge Bearing selection process Bearing failure and how to prevent it 	<p>Tools</p> <ul style="list-style-type: none"> SimPro Quick Bearing Select Engineering Calculator LubeSelect for SKF greases Heater selection tool Oil Injection Method Program Rolling bearings mounting and dismounting instructions
--	---	--